

**COMPUTER AIDED MACHINE DRAWING**

Time: 3 Hours

Max. Marks: 100

Note: 1. Answer any one question from each of the parts A,B,C

2. Use **FIRST ANGLE** projection only.

3. Missing data if any may suitable be assumed

4. All the calculations should be on answer sheet supplied

5. All the dimensions are in mm

6. **Part C Assembled View should be in 3D and the other 2 views in 2D**

PART-A

Q. No. 1 Figure shows a machine component. Draw the following:

- (a) Front view
- (b) Top view and
- (c) Side view from left

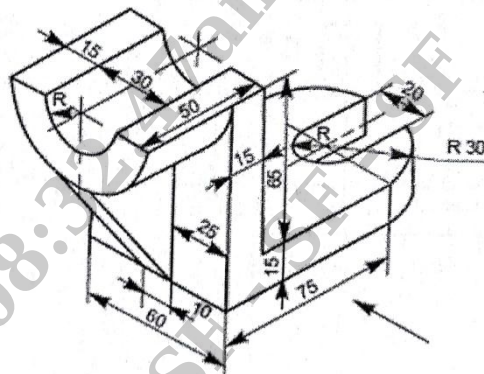
(25 Marks)

Q. No. 2 Draw two views of Square headed bolt with nut of size M25 X 100

(25 Marks)**PART-B**

Q. No. 3 Draw two views of socket and spigot cotter joint of diameter of shaft 25 mm.

(25 Marks)

Q. No. 4 Draw two views of a split muff coupling of diameter of shaft of 25 mm.

(25 Marks)**PART-C**

Q. No. 5 Figure: 1 Shows the details of "Machine Vice". Assemble the parts and draw the following: a) Sectional front view b) Top view

(50 Marks)

Q. No. 6 Figure: 2 Shows the details of "Lever safety Valve". Assemble the parts and draw the following: a) Sectional front view b) Top view

(50 Marks)

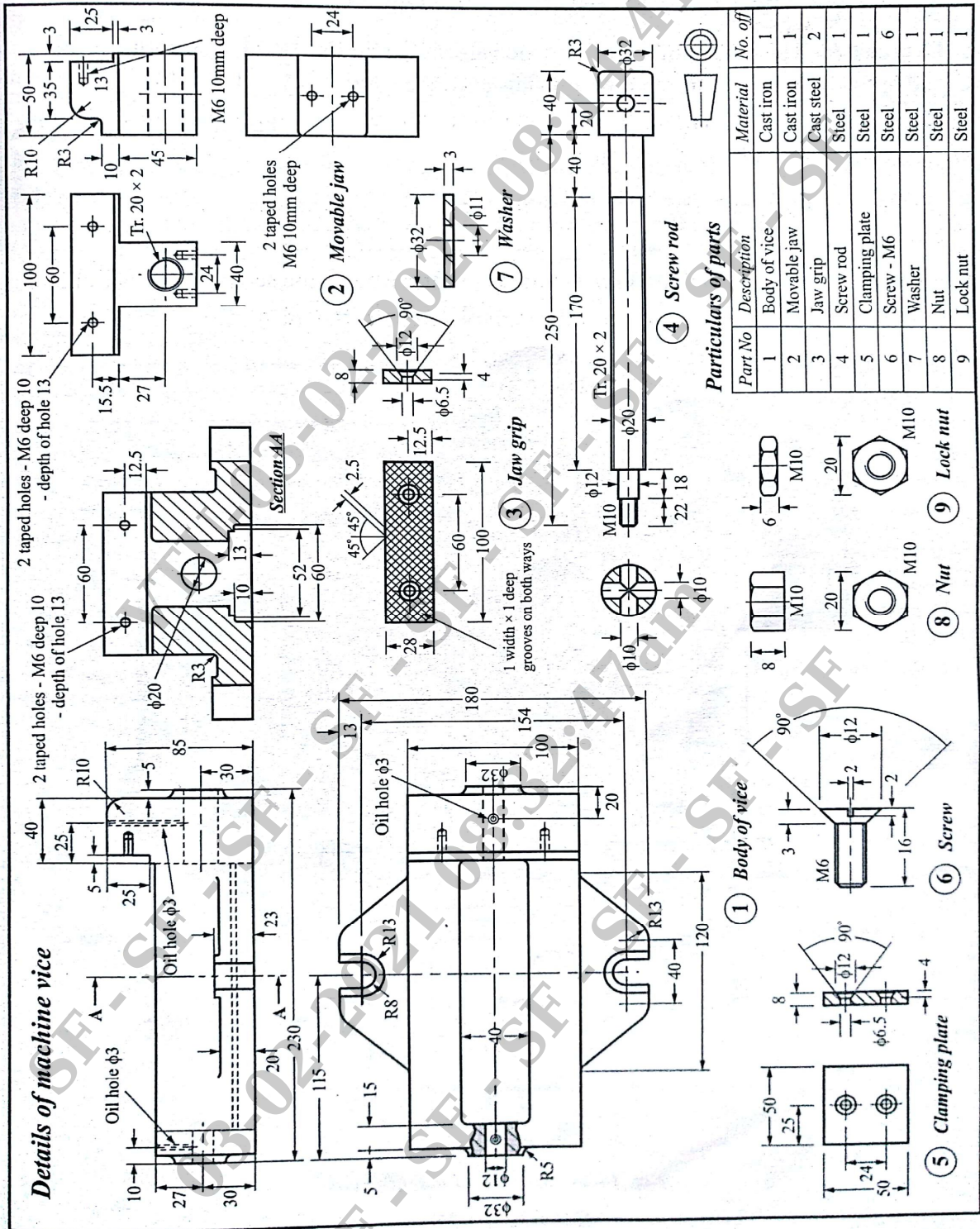
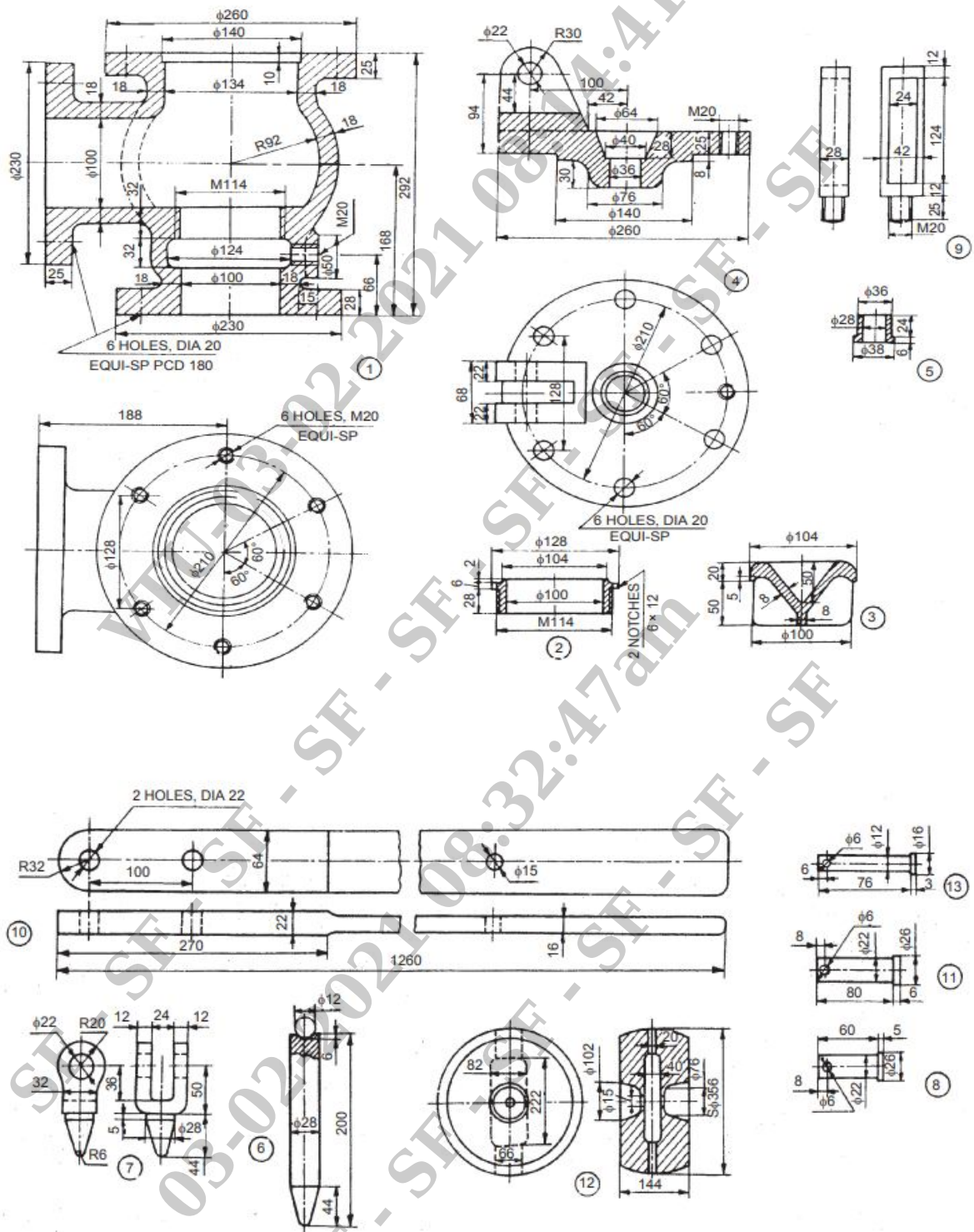

Figure 1: Details of Machine Vice

USN										
-----	--	--	--	--	--	--	--	--	--	--

18ME36A/18MEA306/18MA36/18ME46A



Parts list

Part No.	Name	Matl	Qty	Part No.	Name	Matl	Qty
1	Body	CI	1	8	Toggle-pin	MS	1
2	Valve seat	GM	1	9	Lever guide	MS	1
3	Valve	GM	1	10	Lever	FS	1
4	Cover	CI	1	11	Fulcrum pin	MS	1
5	Cover bush	Brass	1	12	Weight	CI	1
6	Spindle	MS	1	13	Lever pin	MS	1
7	Toggle	MS	1	14	Stud with nut M20	—	6

Figure 2: Details of Lever safety Valve